



1802-14"LX Ballast Stripping Eductor

Materials of Construction:

Body & Diffuser Bronze ASTM B-62
Nozzle Monel or 316 Stainless Steel
Fasteners; 316 Stainless Steel
Gaskets: Neoprene Rubber

Flanges: ANSI 150#	Inlet	Suction	Discharge
ID	10"	10"	14"
OD	16"	16"	21"
# bolt Holes	12	12	12
Hole Diam.	1"	1"	1 1/8"
B.C.	14 1/4"	14 1/4"	18 3/4"

General Operating Conditions

Suction Capacity Up to 6000 GPM
Suction Lift Up to -23 Feet
Discharge Head Up to 120 Feet
Total Head Up to 143 Feet
Motive Head 100-200 PSI
Motive Quantity 4000 – 6000 GPM

Dimensions	A	B	C	D	E	F
	102.8"	9"	93.8"	10 1/2"	31"	54"

Notes:

1. A special VM Nozzle Tool Wrench is required to remove & replace nozzles.
2. Eductor inlet will be integrally Cast into the body section.
3. Nozzle / body connection is threaded. Nozzle is removed & installed with a special VM nozzle wrench. Supplied as a spare part only.
4. Mounting lugs are cast on each part and must be used in installation to support the eductor. Eductor is not designed for pipe loads.
5. Eductors supplied fully assembled.
6. Recommend 8 -10 x pipe diameter of straight section on discharge.
7. For long inlet lines, use 300 and reduce at inlet to 250 mm.
8. Eductor supplied to meet the requirements of each application. Client must insure proper motive pressure & flow are supplied at the eductor nozzle.
9. Suction Lift and discharge head including friction shall not exceed data supplied at time of order. VM is not responsible for changes in operating or installation parameters after orders are placed.
10. Eductor operation is completely dependent on the piping condition into which it is installed. Actual piping shall not vary from design.
11. Customer to advise all piping and friction conditions to insure proper eductor sizing and supply.
12. Client to follow VM installation and operation guidelines.
13. Final Eductor dimensions to be confirmed and advised with Working Drawings, to be supplied prior to shipment of 1st ship set.
14. VM recommends spare nozzle & gaskets as on board spares.

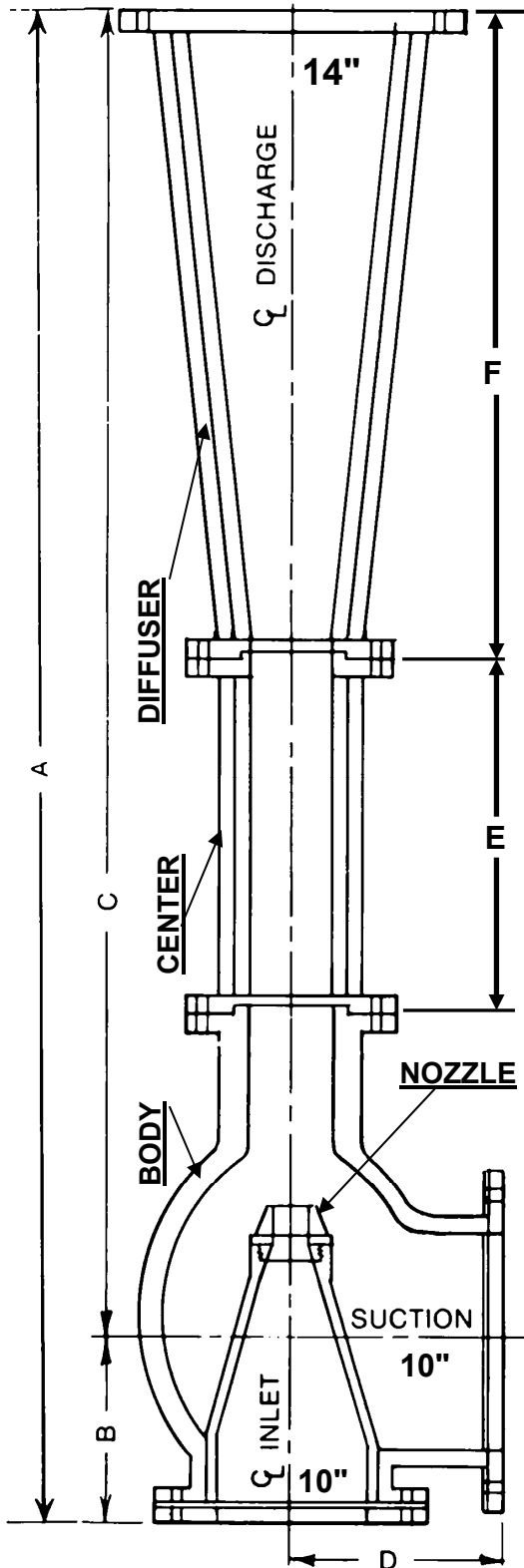

Vita Motivator Co. Inc.

PO Box 8139 Englewood, NJ 07631
 T. 201-567-1151 F. 201-567-1152

www.vitamotivator.com / michaels.greene@att.net

